

3.10 Model M-3219 Mini System (Formerly M-259)

Description

- Pump / Motor / Reservoir / Valve
- Check Valve
- 2-Way/2-Position Normally Closed Solenoid Operated Lowering Valve
- Externally Adjustable Relief Valve
- Outlet Port Options:
Check Valve Port: 7/16-20 SAE O-Ring or
Face Port: 7/16-20 SAE O-Ring
- Horizontal Mounting Standard

Popular Feature:

- Solenoid Lowering Valve is Recessed Into Base and Protected from Abuse

Popular Options

- Hand Pump Manifold Directly to Base. (Shown in Dashed Lines)
- .250 Inch NPT Outlet
- Control Box and Cord
- Vertical Mounting / Motor Up

Schematic

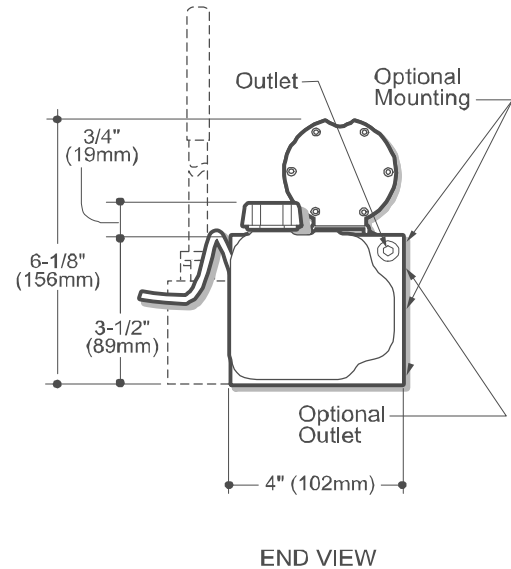
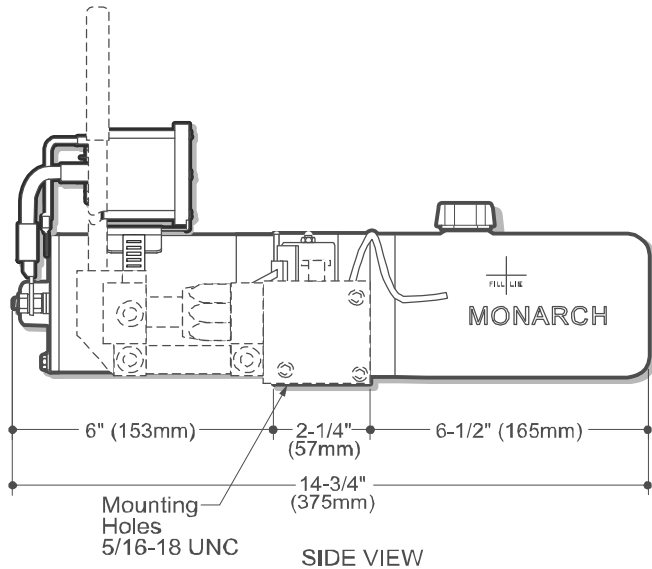
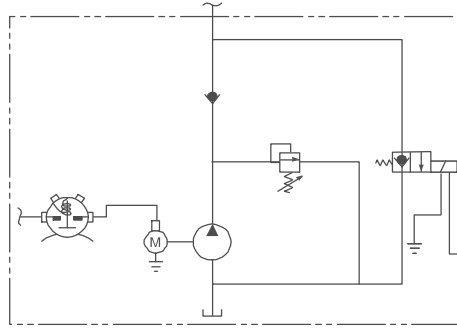

How to Order Your M-3219 Mini System

Comprehensive information may be found on the page referenced below each selection category.

Shown as standard with:

Pump	Motor	Voltage	Reservoir (Length)	Motor Start Switch	Mounting Position	Control Boxes	Optional Hand Pump	Accessories
	08053	12	06230	17757	Horizontal			
Ref. Page 51	Ref. Page 50		Ref. Page 74-84	Ref. Page 87		Ref. Page 88	Ref. Page 91	Ref. Page 90